

Project Summary

Total Site Area:	13.7 Acres
Net Area:	7.1 Acres
Slope + Pahl Road:	6.6 Acres
Total Residential Units (60' x 70' Duplex):	87 DU
Density (Net):	12.3 DU/AC

Residential Parking Required

Duplex	
87 DU x 2.0	174

Residential Parking Provided

Private Garages	174
Driveway	24
Open Parking	37
Total Onsite Parking Provided	235 (2.7/unit)

Assumptions:

1. Standard stall dimension of 9'x18' and parallel space dimension of 8'x22'
2. Setbacks, slopes, parking dimensions, aisle widths and other requirements to be confirmed by civil engineer

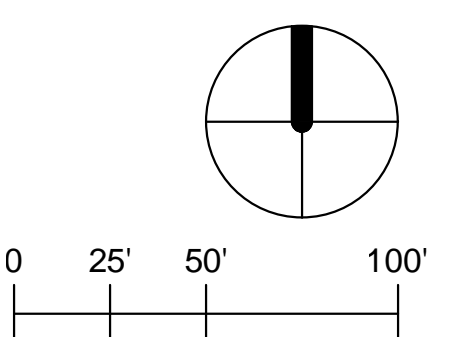

FIREMAN'S CIRCLE

The True Life Companies
 23 Corporate Plaza, Suite 150
 Newport Beach, CA 92660
 949.629.2523

CONCEPTUAL YIELD STUDY - ALT 5

MURRIETA, CA
 KTG # 2015-0868

11.20.2015

KTGY Group, Inc.
Architecture+Planning
 17911 Von Karman Ave., Suite 200
 Irvine, CA 92614
 949.851.2133
 ktgy.com

